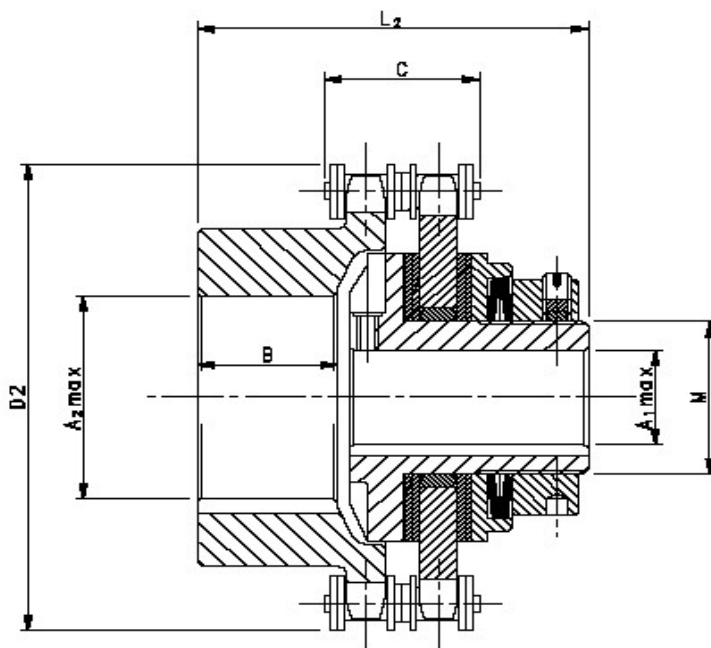
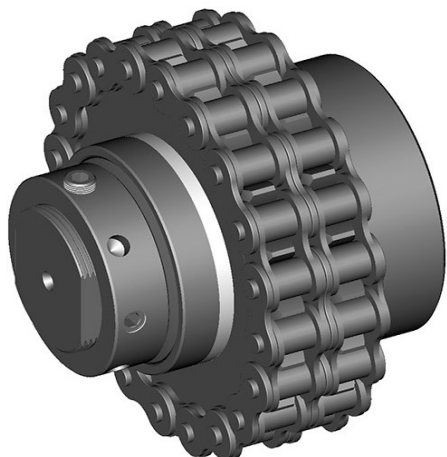

HŘÍDELOVÉ SPOJKY

Spojky s omezovačem Mk

SPOJKY S OMEZOVAČEM Mk

Označení	Typ omezovače M _k	Rozměry (mm)								Vychýlení hřídelí	
		D ₂ max.	L ₂	A ₁ max.	A ₂ min.	A ₂ max.	B	C	M	radiální max. mm	úhlové max. α°
GS 1	LC 1	116	90	24	15	50	26	36	40	0,25	1/2°
GS 2	LC 2	138	106	28	17	60	38	42	45	0,31	1/2°
GS 3	LC 3	184	120	45	26	70	44	68	63	0,38	1/2°
GS 4	LC 4	250	155	65	26	120	68	80	100	0,51	1/2°

HŘÍDELOVÉ SPOJKY

Omezovače Mk

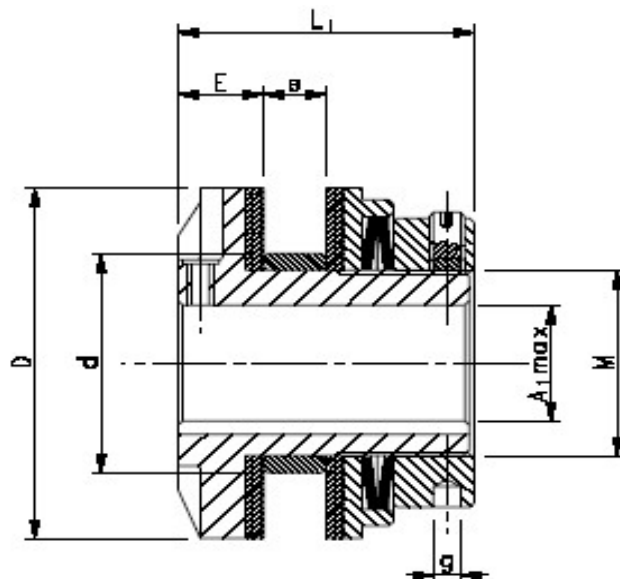

OMEZOVAČE Mk											
Označení	Typ omezovače M _k	Rozměry (mm)								Kruticí moment (Nm)	
		D	L ₁	A ₁ max.	E	e max.	d (g6)	M (h8)	g		
LC 1	LC 1	63	60	24	17	15	48	40	6	10-40	20-80
LC 2	LC 2	85	65	28	19	15	53	45	6	30-100	60-200
LC 3	LC 3	128	70	45	20	18	68	63	8	80-250	160-500
LC 4	LC 4	170	80	65	20	20	110	100	8	200-630	400-1250